

270°

AN-9030

Bestselling product from the 270° E-Gun series

Long-life filament

U-shape, 0.55 Dia, 0.8 Dia, Long-life

Easy maintenance

- Easy-to-clean design
- Filament replacement possible from the top
- Filament socket can be detached from the top
- Easy filament replacement

* Can be used in conjunction with ORIGIN's ISA-7000 product.

* The configuration consists of a single electron gun, and the crucible is sold separately.

* Some layouts may not be installable, so please inquire before placing an order.

* We cannot guarantee the product's performance when used in combination with products from other manufacturers.

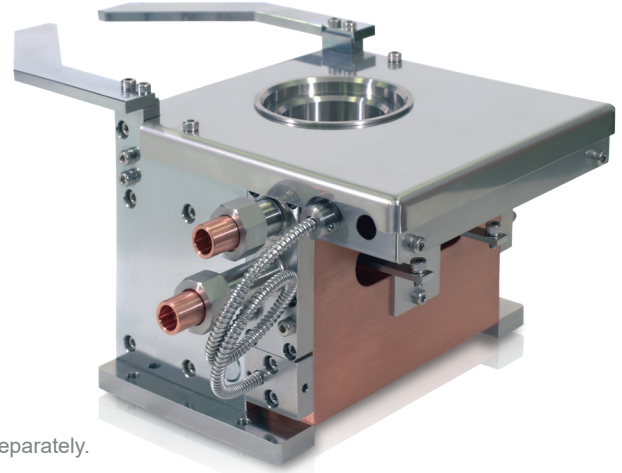

External Dimensions

(Unit: mm)

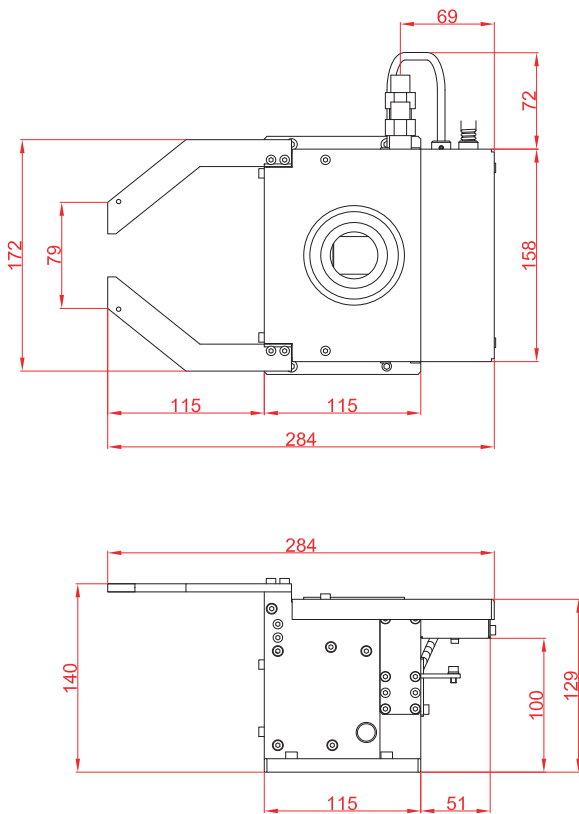

Technical Specifications

Model	AN-9030
Application	Oxide films & Metal films
Beam deflection angle	270°
Maximum output power	10KW
Accelerating voltage	-3000 to -10000Vdc
Beam deflection adjust	Electronmagnet & Deflection adjust bar
Beam deflection current	0 to 2.5A (±30mm)
Deflection max frequency	5KHz -3dB
Beam scanning current X axis	60Hz (X axis) Max output (10App, ±2A dc)
X axis scanning max frequency	10KHz -3dB
Beam scanning current Y axis	60Hz (Y axis) Max output (10App, ±2A dc)
Y axis scanning max frequency	10KHz -3dB
Operation pressure	2Kg / cm ²
Cooling water flow rate	5 to 8 L/min
Filament current	0 to 30A
Ground	Lees than ground resistance 10 ohm
External dimensions (Unit: mm)	172 (W) X 285 (D) X 144 (H)
Weight	Approximately 14kg

